

# Neutrix®

## OPERATION MANUAL



# **NEUTRIX OPERATION MANUAL**

## **Table of contents**

	Page	
1.	Intended use	2
1.1	Specific safety precautions	2
2	Meaning of Symbols	3
3	Layout and designations	4
4	Operational characteristics of the Neutrix WAG40	6
5	Technical data and scope of delivery	6
6	Preparatory steps	7
6.1	Selecting the grinding path	7
6.2	Selecting the electrode diameter	8
6.3	Selecting the grinding angle	8
7	Operation	8
7.1	Starting up	9
7.2	Grinding the tungsten electrode	10
7.3	Safety precautions for tungsten electrodes containing thorium oxide	11
8	Maintenance	12
8.1	Cleaning	12
8.2	Filter replacement	12
8.3	Replacing the diamond disc	13
8.4	Faults	13
9	Spare and wearing parts	14
10	Disposal	16
11	Safety precautions	16
12	EC Declaration of conformity	19
13	Warranty certificate	20
14	Further accessories	21

## 1. Intended use

The Neutrix WAG40 Tungsten Electrode Grinder is solely intended for the purpose of grinding standard TIG welding electrodes. It must not be used other than in the manner described in this operator manual.

You should read this operator manual thoroughly before starting up the machine. You should also familiarise yourself with how it works and how you should operate it. You must maintain the machine in accordance with the instructions so that it continues to function correctly at all times. The operator manual must be kept close to the machine.

### 1.1 Specific safety precautions

When using the unit, always observe the local safety regulations to prevent fire hazards, electric shock and injuries. In addition to the specific safety regulations listed below, you must also read the information under Safety precautions.



For your own protection and for the purpose of protecting the machine, must observe any sections of text that are highlighted by means of this symbol.

- Before starting up the equipment, check it for visible signs of damage or deficiencies
- Never operate the unit without a filter cartridge.
- When replacing a filter cartridge, always follow the instructions in the operator manual
- Only operate the unit with the electrode holder located in the admission channel
- On completion of the grinding process, only remove the electrode holder once the unit has run down.
- Correct deficiencies and repair damage immediately
- Work on the electrical equipment must only ever be carried out by a qualified electrical expert
- Never use the unit in a damp environment, in the rain, etc.
- Only ever use original spare parts and accessories
- Always disconnect the mains lug before carrying out maintenance/repair work or replacing filters/grinding discs as well as after use.
- Ensure that the unit cannot be started up unintentionally
- When plugging into the mains, ensure that the switch is set to OFF
- Always wear safety goggles during operation
- You must wear ear protection when using the machine

## 2. Meaning of Symbols



For your own protection and for the purpose of protecting the machine, you must observe any sections of text that are accompanied by this symbol.



You must read the operator manual before starting up the unit



Protect your eyes. During operation, wear safety goggles.



Protect your ears. You must wear ear protection when using the machine!



This unit has been CE tested.

### 3. Layout and designations

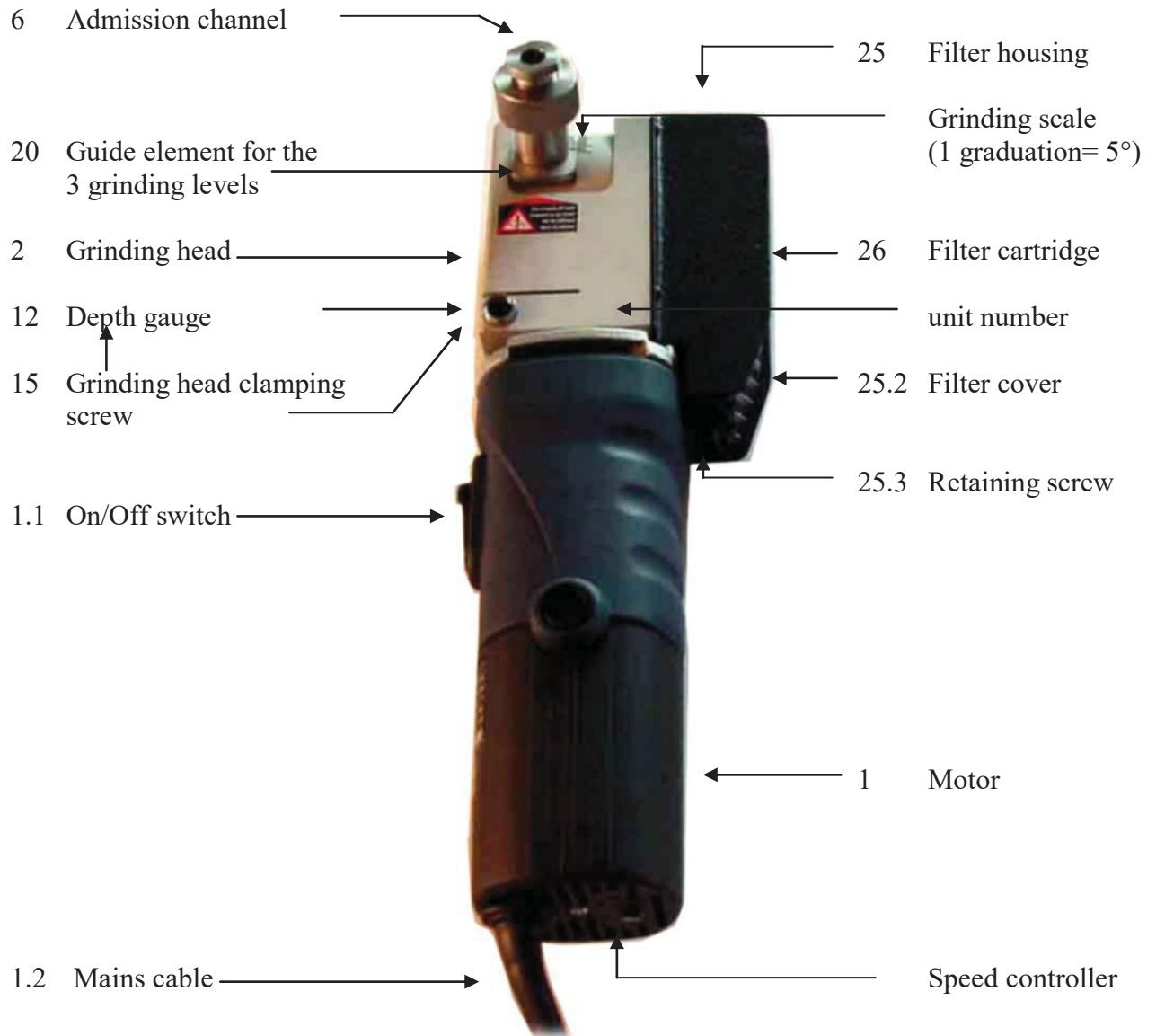

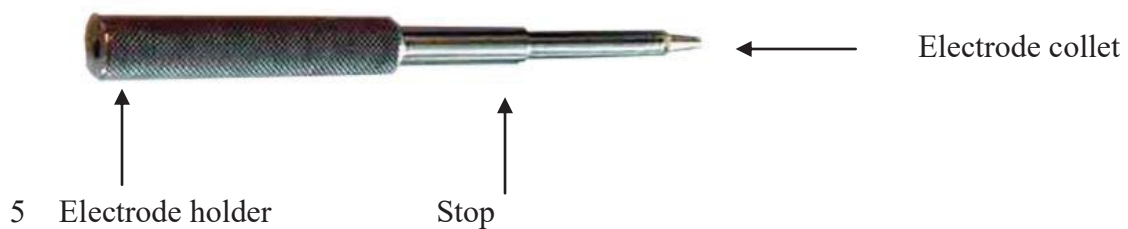
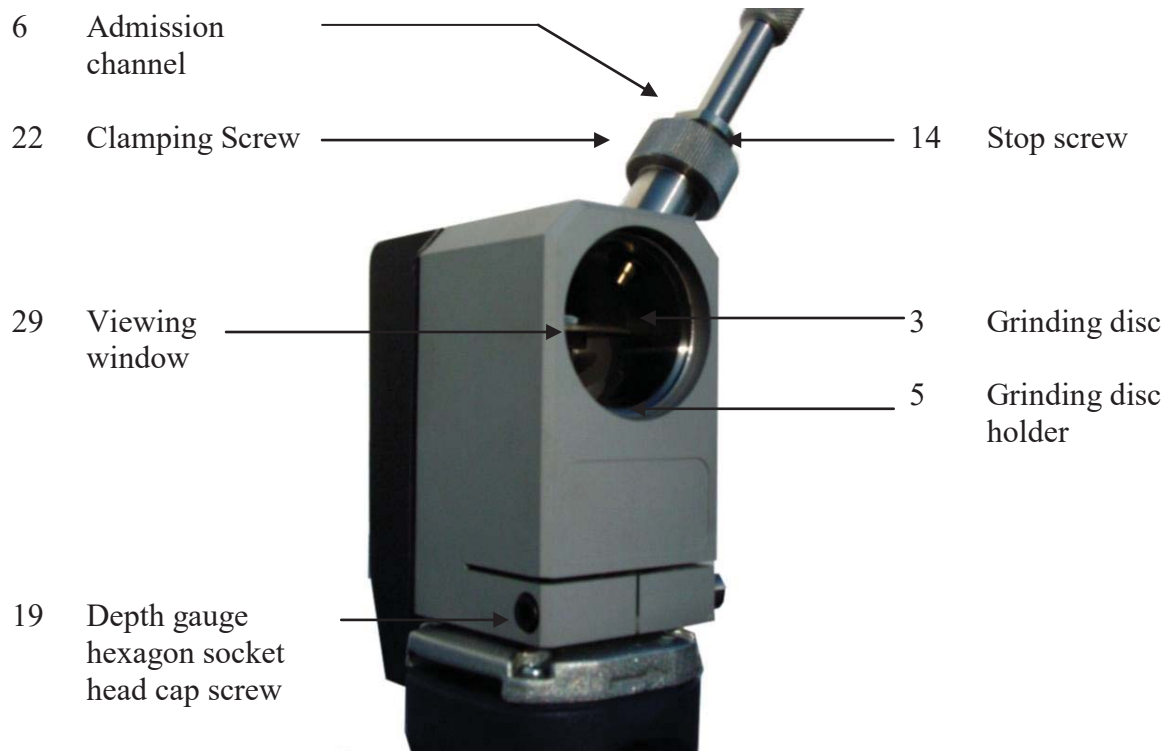

Collet Electrode diameter

16.1	for	1.0 mm
16.2	for	1.6 mm
16.3	for	2.0 mm
16.4	for	2.4 mm
16.5	for	3.2 mm
16.6	for	4.0 mm

#### 4. Operational characteristics of the WAG40

The Neutrix WAG40 is intended for the sole purpose of grinding TIG welding electrodes.

When handling thoriated tungsten electrodes, you must observe the relevant health and safety rules issued by the Accident Prevention & Insurance Association (see paragraph 7.3: Handling tungsten electrodes containing thorium oxide within the context of the TIG tungsten inert gas welding method).

- Suitable for electrode diameters of between 1,0 – 4,0 mm.
- Supports infinitely variable angle adjustment from 15° to 180°.
- Features a depth gauge for minimal electrode wastage.
- Suitable for electrode lengths of up to 15mm.
- Ensures optimal and precise longitudinal grinding.
- Suitable for use as a table-mounted or hand-held unit.
- Features an integrated replacement filter (Type: 8511 K1.H12) for swarf.

#### 5. Technical data & scope of delivery

Power P1: 850 Watt  
Mains connection: 230V, 50 Hz. Insulation according to EEC 50144.  
Rpm: Adjustable between 8.000 rpm to 22.000 rpm  
Lpa sound pressure level: 88.8 dB(A)  
Vibration value: 5 m/s<sup>2</sup>  
Weight: 3,8 kg  
Filter cartridge: Disposable filter.  
Diamond disc: Ø 40 mm

Transport case containing

- **Neutrix WAG40** - Grinding head complete with drive motor
- **Accessories** - Electrode holder  
Collets for electrodes with Ø of 1,6/2,4/3,2 mm
- **Service tools** - 8mm Allen key  
- 4mm Allen key  
- 13/17 open-end wrench  
- 13/14 open-end wrench
- **Refuse bag for disposable filter**

## 6. Preparatory steps



Read the operator manual:



Observe the safety precautions!

### 6.1 Selecting the grinding path

Depending on how worn the diamond disc is, you have a choice of 3 grinding paths.

- Loosen the clamping screw (22) manually
- Lift up the guide element (20) turn it in the required direction by 90° at a time and press it into the angle guide (grinding angle scale)
- Refasten the clamping screw (22)

#### Guide element for 3 grinding levels

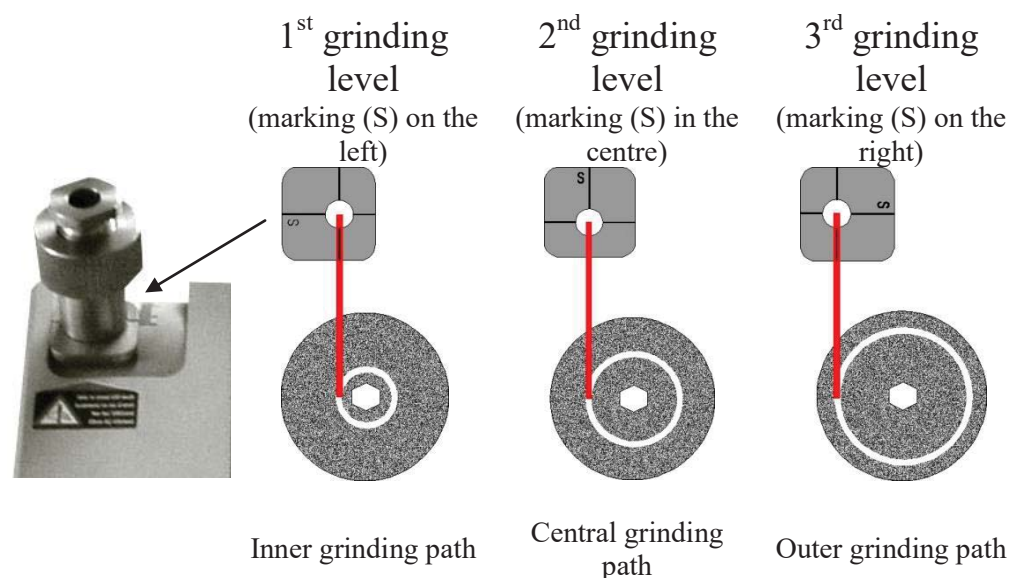

**Attention:** To ensure optimum utilisation of the grinding disc, you should start off by using the inner grinding path (figure 1), then proceed to the central grinding path (figure 2) and finish off with the outer grinding path (figure 3). The manufacturer's basic setting is the inner grinding path.



## 6.2 Selecting the electrode diameter

Screw the appropriate collet,  $\varnothing$  1 to 4 mm, (Item 16.1-16.6) into the electrode holder.

The collet for the  $\varnothing$  2,4 mm electrode is the one, that is fitted into the electrode holder (5) when the machine is supplied. The  $\varnothing$  1,6 and  $\varnothing$  3,2 mm collets are also included in the scope of delivery.

## 6.3 Selecting the grinding angle

- Loosen the clamping screw (22) slightly
- Align the degree mark on the guide element (20) with the desired angle on the grinding angle scale
- Tighten the clamping screw (22).

**Attention:** An angle of  $15^\circ$  corresponds to the smallest angle on the electrode.

An angle of  $180^\circ$  corresponds to a rectangular surface on the electrode point (one graduation =  $5^\circ$ ).

## 7. Operation



Always observe the safety precautions and comply with the applicable regulations. When operating the Neutrix WAG40 machines, you must ensure correct ventilation across the entire filter area. If the Neutrix WAG40 is to be operated when stationary in a fixed, clamped support, it must be moved into the horizontal position.

**Only operate the tungsten electrode grinder in a level position. This ensures that the swarf settles in the filter cannot get inside the unit.**

To make the precise electrode grinding settings use the grinding head clamping screw's (15) depth gauge (12). Whenever you are about to start a new grinding process, you must repeat the setting procedure



- Before you switch on the unit, you must always ensure that the electrode holder (5) is located in the admission channel (6).



- You must switch off the machine and let it run down before you attempt to remove the electrode holder.

## 7.1 Starting up



- Before starting up the unit, check that the mains voltage and mains frequency given on the rating plate match your mains supply.
- The unit must only be connected to sockets with an earthing contact. Radio interference suppression conforms to European standard EN 55014.



- When plugging the unit into the mains, ensure that the switch is set to OFF.
- Connect the unit to the power supply. Set the speed in accordance with the table
- Insert the tungsten electrode into the electrode holder (5) so that it protrudes by approx. 35mm
- Insert the electrode holder into the depth gauge (12) until the collet (16.1-16.6) makes contact with the grinding head clamping screw (15). In order to clamp the tungsten electrode securely in place, turn the electrode holder (5) to the right.
- Insert the electrode (5) into the admission channel (6) until the tungsten electrode is located over the grinding disc (3). To check this, use the viewing windows (29).
- Switch the unit ON



You should avoid pressing the electrode too firmly onto the grinding disc (3), before the stop (14a) on the electrode holder has been reached. Before you switch on the unit, you must always ensure that the electrode holder (5) is located in the admission channel (6).



You must switch off the unit and let it run down before you attempt to remove the electrode holder (5). Failure to comply with this instruction could result in swarf being released from the admission channel (6)/becoming lodged in the admission channel. Then, the next time the electrode holder (5) is inserted, it will get jammed inside the admission channel (6) because of the swarf deposits.



### **Noise measurement:**

The A-weighted, equivalent continuous sound pressure level at the work place exceeds 70 dB(A). Measured in accordance with EN ISO 11201.

You must always wear ear protection when using the tungsten electrode grinder!

## 7.2 Grinding the tungsten electrode

- Move the electrode holder towards the grinding disc at low speed, so that the tungsten electrode does not glow. To check this, use the viewing window (29).
- Grind the electrode by applying a small amount of pressure and turning the electrode holder (5) slowly and evenly.
- The grinding process is complete as soon as the stop (14a) on the electrode holder has been reached and the tungsten electrode is no longer in contact with the grinding disc (3).
- Switch off the unit and let it run down.
- Remove the electrode holder and insert it into the depth gauge (12).  
To release the tungsten electrode, turn the electrode holder to the left.

Attention: Beads on the tip of the electrode, e.g. as a result of immersing it in the molten metal, must be removed prior to grinding.

**Table 1 – Grinding speed guide values**

	1.0 mm	1.6 mm	2.0 mm	2.4 mm	3.2 mm	4.0 mm
Electrode diameter						
Speed adjustment	2	2	2	2	3	3

### 7.3 Safety precautions for tungsten electrodes containing thorium oxide



When grinding tungsten electrodes containing thorium oxide, radioactive dust is released, which is linked to the risk of internal radiation exposure if the dust is inhaled!



- 1. Only ever use the grinder with the fitted filter**  
Do not grind any tungsten electrodes containing thorium oxide if the filter housing is not mounted or the filter cartridge has been removed.
- 2. Avoid stirring up dust containing thorium oxide at all costs**  
When carrying out service and maintenance work (e.g. replacing the filter cartridge), make sure that no dust containing thorium oxide is stirring up or inhaled.
- 3. Carry out the following activities outdoors only**  
Replacing the filter cartridge  
Replacing the grinding disc  
Purging the grinding head  
**Wear a dust mask for this in accordance with EN 149**
- 4. Avoid direct contact with the skin with dust containing thorium oxide**  
Wear gloves when carrying out service and maintenance work

Standardised colour coding for tungsten electrodes containing thorium oxide

Code	Oxide additives % (m/m)	Type of additive	Colour code
WT4	0,35 – 0,55	Thorium dioxide ThO <sub>2</sub>	Blue
WT10	0,80 – 1,20	Thorium dioxide ThO <sub>2</sub>	Yellow
WT20	1,70 – 2,20	Thorium dioxide ThO <sub>2</sub>	Red
WT30	2,80 – 3,20	Thorium dioxide ThO <sub>2</sub>	Violet
WT40	3,80 – 4,20	Thorium dioxide ThO <sub>2</sub>	Orange

## 8. Maintenance



Always unplug the unit from the mains socket before carrying out any maintenance work. You will be able to prolong your machine's operation life by having it serviced regularly by a professional.

### 8.1 Cleaning

Clean your machine regularly with a soft cloth.  
The grinding head should only be purged via the admission channel or by blowing compressed air.



The filter and grinding disc should be replaced outdoors!  
If you do decide to replace them in an enclosed space, then you must wear a dust mask in accordance with EN 149.

The protective earth connection on the motor's front end plate is subject to the test specification laid down by DIN VDE 0702T.1.

### 8.2 Filter replacement



Before attempting to replace the grinding disc, you must read Section 8 carefully and comply with the information provided.

#### **Filter replacement is recommended:**

- When you change the grinding path setting from the inner to the central setting.
- Or when you can no longer observe the grinding process through the viewing window.

#### **Procedure:**

1. Undo the retaining screw on the filter housing.
2. Lift up the retaining grille and remove.
3. Remove the filter cartridge and use the refuse sack to dispose of it in the proper manner.
4. Insert the new filter cartridge into the filter housing so that the filter's rubber gasket seals on the grinding head.
5. Hook the retaining grille on at the top and fold it down. Tighten the retaining screw.

### 8.3 Replacing the diamond wheel



Before attempting to replace the grinding disc, you must read Section 8 carefully and comply with the information provided.

1. Remove the electrode holder (5).
2. Use open-end wrench (SW17) to remove the stop screw.
3. Remove the link (10) and viewing window (29) by pulling them towards you.
4. Use the first open-end wrench (SW14) to move the grinding disc (3) to the left and the second (SW13) to move it to the right and remove.
5. Push new grinding disc (3) onto shaft end and tighten.
6. Push link (19) and viewing window (29) into grinding head (2).
7. Use open end wrench (SW17) to tighten stop screw (14) on link (10).
8. Insert electrode holder (5) into stop screw (14)
9. Carry out a trial run – switch the machine off immediately in the event of any sign of abnormal operation.

### 8.4 Faults

In the event of faults (e.g. a fault resulting from a worn out part), please contact your local dealer.

## 9. Spare and wearing parts

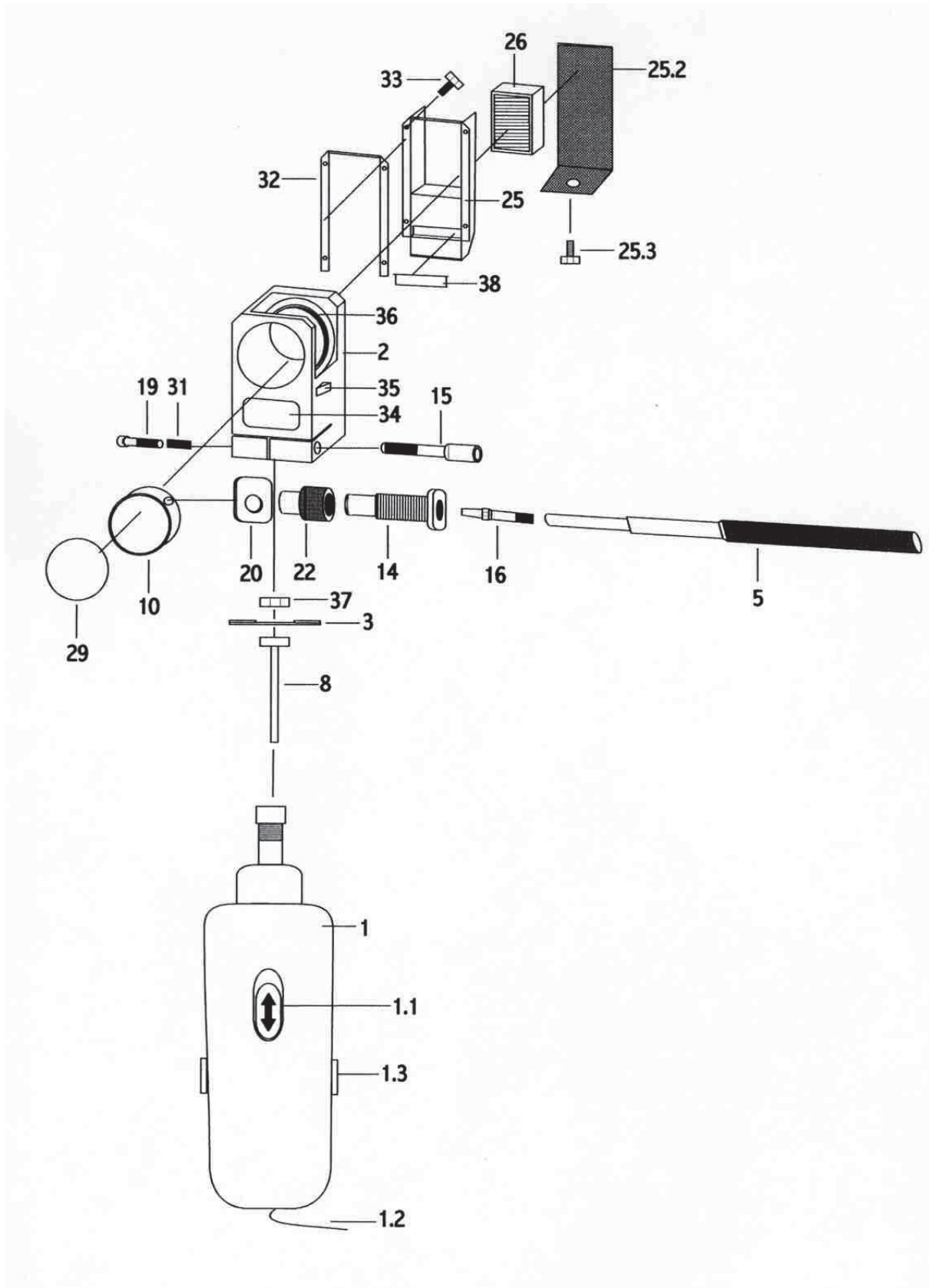

Pos.	Description		Part No.
0	Neutrix WAG 40	1 piece	44-07-WAG 40
1	Motor	1 piece	44-07-44510010
1.1	On/Off switch	1 piece	44-07-44510011
1.2	Power cable	1 piece	44-07-44510012
1.3	Brush for motor	2 pieces	44-07-44510019
2	Grinding head	1 piece	44-07-44510020
3	Diamond wheel Ø 40 mm	1 piece	44-07-44510030
5	Electrode holder	1 piece	44-07-44510050
8	Spindle for diamond wheel (SW 13)	1 piece	44-07-44510080
10	Grinding chamber	1 piece	44-07-44510100
14	Guide for electrode holder (SW 17)	1 piece	44-07-44510140
15	Allen key to tighten the grinding head	1 piece	44-07-44510150
16	See below		
16.2	Electrode clamp Ø 1,6 mm	1 piece	44-07-44510162
16.4	Electrode clamp Ø 2,4 mm	1 piece	44-07-44510164
16.6	Electrode clamp Ø 3,2 mm	1 piece	44-07-44510165
19	Allen screw (M5 x 30)	1 piece	44-07-44510190
20	Eccentric plate to select grinding position	1 piece	44-07-44510200
22	Screw	1 piece	44-07-44510220
25	Filter housing	1 piece	44-07-44510250
25.2	Filter cover	1 piece	44-07-44510252
25.3	Allen key to fix the filter cover (M 5 x 6)	1 piece	44-07-44510330
26	Filter cassette	1 piece	44-07-44510260
29	Inspection cover	1 piece	44-07-44510290
31	Spring	1 piece	44-07-44510310
32	Rubber seal big	1 piece	44-07-44510320
33	Screw to fix filter cassette	4 pieces	44-07-44510330
34	Sticker „Neutrix“	1 piece	44-07-44510340
35	Safety sticker	1 piece	44-07-44510350
36	Degree scale	1 piece	44-07-44510360
37	Screw to fix diamond wheel (M 8, SW 13)	1 piece	44-07-44510370
38	Rubber seal small	1 piece	44-07-44510380

### **Accessories**

39	Case for machine with foam	1 piece	44-07-45510390
40	Spanner (SW 13, SW 17)	1 piece	44-07-45510400
41	Spanner (SW 13, SW 14)	1 piece	44-07-45510410
42	Allen key 8 mm	1 piece	44-07-45510420
43	Allen key 4 mm	1 piece	44-07-45510430
44	Plastic bag for disposal of filter	1 piece	44-07-45510440
16.1	Electrode clamp Ø 1,0	1 piece	44-07-45510171
16.3	Electrode clamp Ø 2,0	1 piece	44-07-45510172
16.5	Electrode clamp Ø 3,0	1 piece	44-07-45510173
16.7	Electrode clamp Ø 4,0	1 piece	44-07-45510174



## 10. Disposal

Only for EU countries



Do not dispose of electric tools together with household waste material!

In observance of European Directive 2002/96/EC on waste, electrical and electronic equipment and its implementation in accordance with national law, electric tools that have reached the end of their service life must be collected separately and returned to an environmentally compatible recycling facility.

## 11. Safety precautions

Attention: When using the machine you must observe the following fundamental safety precautions to protect yourself against electric shock, injury and fire hazards.

**Read this information carefully and commit it to memory before using the unit. Keep the safety precautions in a safe place!**

- 1. Keep your work area tidy**  
Untidy work areas can cause accidents.
- 2. Take environmental factors into account**  
Never expose the machine to rain. Never use the unit in a wet or damp environment. Ensure a good level of lighting. Never use the machine in the vicinity of combustible liquids or gases.
- 3. Protect yourself against electric shock**  
Avoid bodily contact with earthed parts, e.g. pipes, heaters, ovens, refrigerators.
- 4. Keep children away.**  
Do not allow other people to touch the machine or cables, keep them well away from the work area.
- 5. Store your machine safely and securely**  
When not in use, machines should be stored in a dry, locked area that is not accessible to children.
- 6. Never overload your machine**  
You will be able to work more effectively and safely by adhering to the specified performance range.

- 7. Wear suitable work clothes**  
Do not wear loose-fitting clothing or jewellery, as they can get caught in moving parts. When working outside, you should wear sensible, non-slip footwear. If you have long hair, you must wear a hairnet.
- 8. Wear safety goggles**  
Use a breathing mask whenever dust is likely to be generated.
- 9. Do not abuse the cable**  
Do not carry the machine by the cable or use it to pull the plug out of the socket. Protect the cable against heat, oil and sharp edges.
- 10. Secure the machine**  
Use work-holding devices or a vice to secure the workpiece. This is a more stable approach than simply using your hand, and also leaves you with both hands free to operate the machine.
- 11. Do not overextend yourself**  
Adopt a natural posture. Make sure that you stand securely and maintain your balance at all times.
- 12. Take proper care of your machine**  
Keep your machine clean so that it will continue to provide safe and reliable operation. Follow the maintenance instructions and other information relating to maintenance work. Inspect the plug and cable on a regular basis and get them repaired by a qualified expert in the event of damage. Inspect extension cables regularly and replace if damaged. Keep the machine housing dry and free of oil and grease.
- 13. Disconnect the mains plug**  
When the machine is no longer in use, or if maintenance work needs to be carried out.
- 14. Do not leave tool keys behind**  
Before switching on the unit, check that all keys and adjusting tools have been removed.
- 15. Avoid unintentional starting**  
Keep your finger away from the switch when carrying a machine that is plugged into the mains. When plugging the unit into the mains, ensure that the switch is set to OFF.
- 16. Outdoor Extension cables**  
When working outdoors, only use approved extension cables that have been marked as appropriate for outdoor use.
- 17. Stay alert**  
Keep a close eye on what you are doing. Proceed with care. Do not use the machine if you feel unable to concentrate.
- 18. Inspect your unit for damage**  
Before continuing to use the machine, you must carefully check that any safety equipment or parts that have suffered minor damage are still

capable of operating correctly and in accordance with their intended purpose. Check that all moving parts are in proper working order, that they are not jammed in any way and that no parts have been damaged. All parts must be fitted correctly and all the conditions necessary for ensuring fault-free operation of the unit must be met. Unless otherwise specified in the operator manual, any protective devices or parts that have been damaged must be professionally repaired or replaced by an authorized service workshop. Damaged switches must be replaced at an authorized workshop. Do not use any kind of tool if the switch cannot be turned ON and OFF while they are in use.

**19. Attention**

For your own safety, only use accessories and additional equipment specified in the operator manual or recommended or specified by the machine manufacturer.

**20. Repairs must only ever be carried out by a qualified electrical expert**

This machine complies with the relevant safety regulations. Repairs must only ever be carried out by a qualified electrical expert; otherwise, the operator is at risk of injury.

## 12. EC Declaration of conformity

In accordance with Machinery directive 2006/42/EX, Appendix IIA

The machine: Tungsten electrode Grinder

Type: Neutrix WAG40/WAG40S/WAG40SW

Supplied complies with the following applicable regulations:

EC Machinery Directive 2006/42/EC,

EC Low-Voltage Directive 2006/95EC,

EC EMC Directive 2004/108/EC, RoHS2 Richtlinie 2011/65/EU

Manufacturer: **Manohr Schweißtechnik GmbH**  
Wiesenstraße 24  
D-15537 Grünheide/ OT Fangschleuse  
Tel.: + 493362/6246

**The following harmonised norms have been applied:**

- DIN EN ISO 12100-1
- DIN EN ISO 12100-2
- DIN EN ISO 13857
- DIN EN 50144-1
- DIN EN 61000-6-1 bis 4

Person responsible: Uwe Manohr  
Director



Manohr Schweißtechnik GmbH

### 13. Warranty certificate

	<b>User:</b>	
	<b>Street:</b>	
	<b>Zip, City:</b>	
<b>Company</b>	<b>Country:</b>	

<b>Article – No.:</b>	
<b>Description:</b>	
<b>Machine No.:</b>	
<b>Date of purchase:</b>	

<b>Error:</b>

**City, date**

**Signature:**

**In case of warranty claims please forwards this certificate to:**

**Manohr Schweißtechnik GmbH  
Wiesenstraße 24  
D-15537 Grünheide/ OT Fangschleuse  
Fax + 493362/28035**

#### 14. Further accessories:

A solid base stabilizes the unit during the grinding process



Stand (S) for Neutrix WAG40  
Item No.: 44-07-45510250



Stand (SW) for Neutrix WAG40  
With tool holder  
Item No.: 44-07-45510252

Notes:

# Die Neutrix® - Reihe

